

DISPENSA Junior III



<http://support.kesseboehmer.de/dispensa-junior-3>

Montageanleitung

Kesseböhmer-D

Mounting Instructions

Kesseböhmer-D

Notice de montage

Kesseböhmer-D

B
300
400
450
500
600

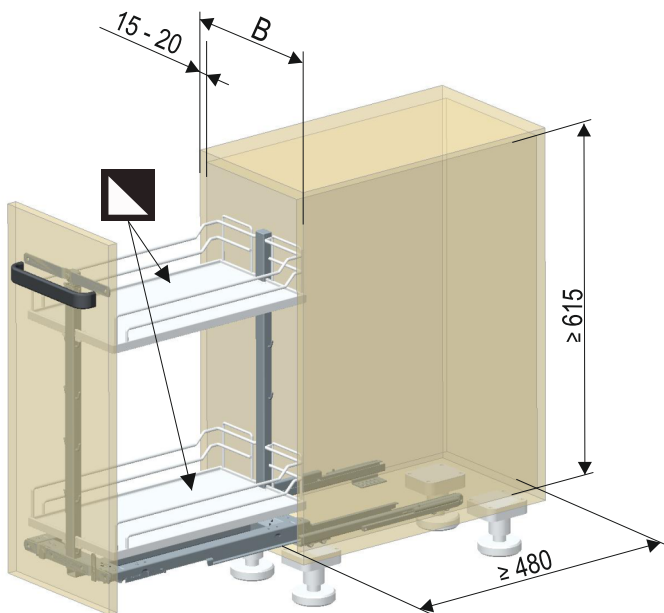
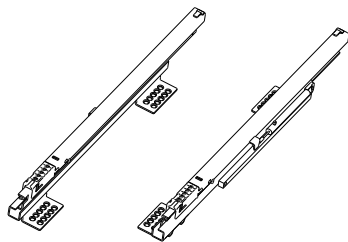

B
300
400
450

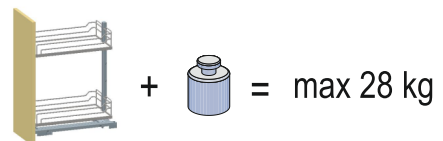
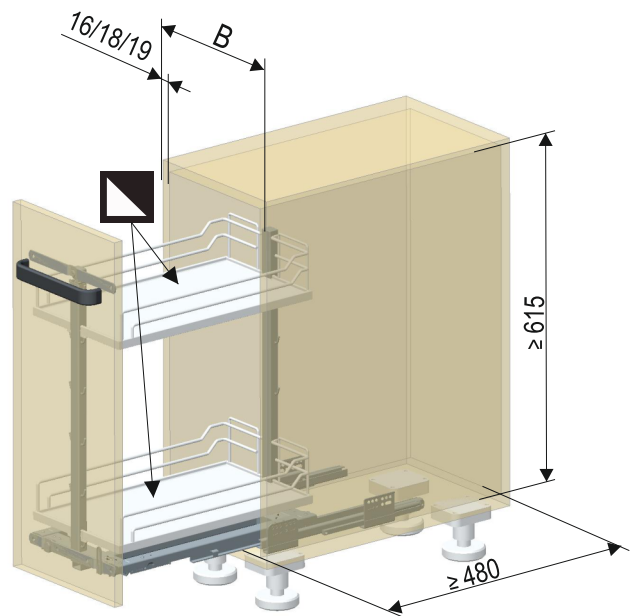
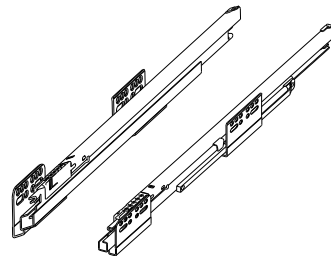

Eigengewicht + Beladung
Empty weight + Load
Poids + Chargement



Symbole • Symbols • Symboles • Simboli • Símbolos • Símbolos • Merkit • Symboler • Symboly • Symbole
Символы • Semboller • Σύμβολα • 記号 • 标志

	DE Warnung! IT Avvertenza! FI Varoitus! PL Ostrzeżenie! TR Uyan! JP 警告	UK Warning! ES ¡Advertencia! DK Advarsel! RU Внимание! GR Προειδοποίηση!	FR Avertissement! PT Aviso! CZ Výstraha!
CN 警告！		UK Incorrect! ES ¡Incorrecto! DK Ikke korrekt! RU Неправильно! GR Οχι σωστό!	FR Incorrect! PT Incorrecto! CZ Nesprávně!
CN 不正确！		UK Correct! ES ¡Correcto! DK Korrekt! RU Правильно! GR Σωστό!	FR Correct! PT Correcto! CZ Správně!
CN 正确！		UK Secure/Secured! ES ¡Fijar/fijado! DK Spænde/spændt RU Заблокировать / заблокировано! GR Στερέωση/στερεωμένο!	FR Fixer/fixé PT Fixar/fixo! CZ Upevnit/upevněno!
CN 锁紧/已锁紧！		UK Release/Released! ES ¡Soltar/suelto! DK Løsne/løsnet RU Разблокировать / разблокировано! GR Λύσιμο/λυμένο!	FR Détacher/détaché PT Soltar/solto! CZ Povolit/povoleno!
CN 松开/已松开！		UK Do not use a cordless screwdriver! ES ¡No utilizar taladro atornillador! DK Brug ikke batteriskruetrækker! RU Не использовать шуруповерт с аккумуляторным питанием! GR Μη χρησιμοποιείτε επαναφορτιζόμενο κατσαβίδι!	FR Ne pas utiliser de tournevis à piles PT Não usar aparafusadora sem fio! CZ Nepoužívejte akušroubovák!
CN 不可使用电动螺丝刀！		UK Use a P22 screwdriver! ES ¡Utilizar un destornillador P22! DK Brug P22-skrueetrækker! RU Использовать отвёртку P22! GR Χρησιμοποιείτε κατσαβίδι P22!	FR Utiliser un tournevis P22 PT Usar chave de parafusos P22! CZ Použijte křížový šroubovák P22!
CN 请使用P22螺丝扳手！		UK Optional element! ES ¡Elemento opcional! FI Valgfrít elementti! RU Необязательный элемент! GR Προαιρετικό στοιχείο!	FR Élément optionnel PT Elemento opcional! CZ Volitelný prvek!
CN 可选件！		UK Alternative element! ES ¡Elemento alternativo! FI Vaihtoehtoinen elementti! RU Альтернативная деталь! GR Εναλλακτικό στοιχείο!	FR Élément alternatif! PT Elemento alternativo! CZ Alternativní dílec!
CN 备用件！		UK Audible click on engagement! ES ¡Cuando encaja se oye un clic! DK Kliklyd ved monteringen! RU Щелчок при фиксации! GR Να ακουστεί κλικ κατά την ασφάλιση!	FR «Clic» lors de l'encliquetage PT Ruído de clique ao engatar! CZ Slyšitelné zavaknutí!
CN 嵌入时有咔嚓声！		UK All dimensions in mm! ES ¡Todas las medidas son en mm! DK Alle mål er mm! RU Все размеры в мм! GR Όλες οι διαστάσεις σε mm!	FR Toutes les dimensions en mm! PT Todas as medidas em mm! CZ Všechny rozměry v mm!
CN 所有尺寸单位均为毫米！			



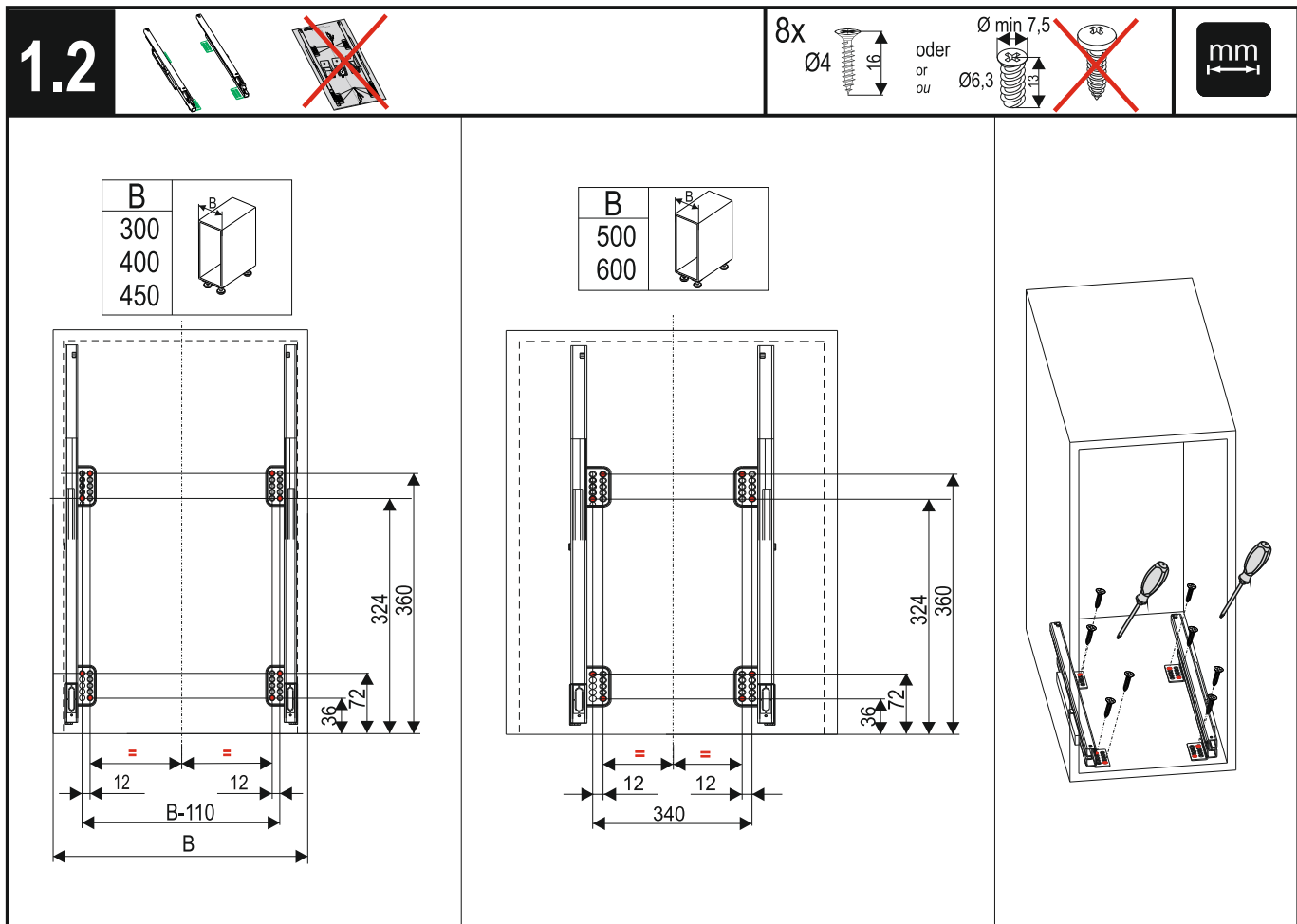
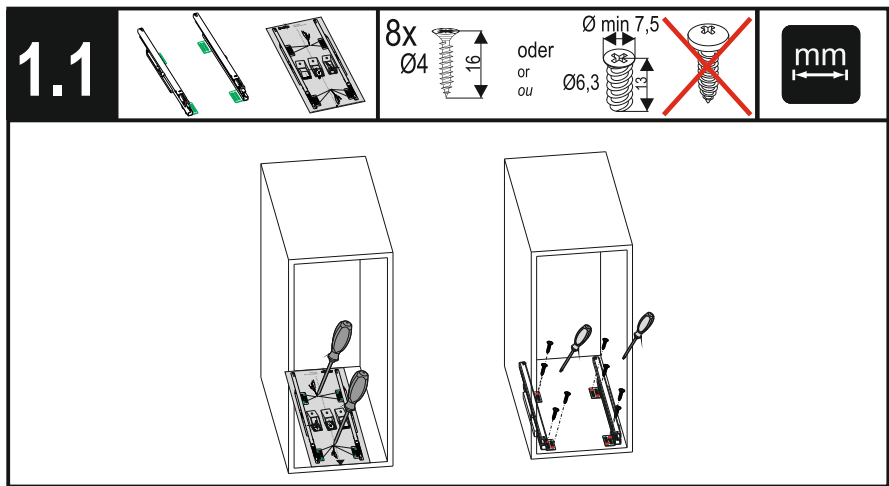
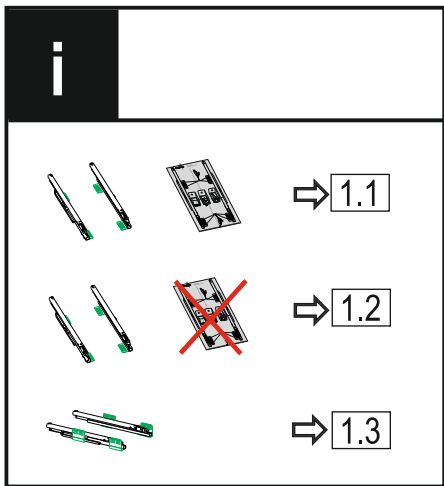

DE Die technischen Darstellungen und Maßangaben – auch bei Abbildungen und Zeichnungen – sind unverbindlich. Konstruktionsverbesserungen sind vorbehalten! **UK** Technical information and stated dimensions (including in illustrations and drawings) must not be regarded as binding. Design subject to change without notice (in interest of improvement)! **FR** Les illustrations techniques et les cotes – y compris sur les schémas et les dessins – sont non contractuelles. Sous réserve d'améliorations de la construction! **IT** Le rappresentazioni tecniche e le indicazioni delle dimensioni – anche nelle figure e nei disegni – non sono vincolanti. Con riserva di miglioramenti di progettazione! **ES** Las descripciones técnicas y los datos dimensionales, inclusive los incluidos en fotos y figuras, son meramente orientativos y no vinculantes. ¡Reservado el derecho a mejoras constructivas! **PT** As descrições técnicas e as indicações de medidas – também em ilustrações e desenhos – não são de natureza imperativa. Salvo melhoramentos de construção! **FI** ekniset piirrokselta ja mitat – myös kuvissa ja piirroksissa olevat – ovat sitoumuksetta. Oikeus tekniisiin parannuksiin pidätetään! **DK** De tekniske fremstillinger og måleangivelser – også i figurer og tegninger – er vejledende. Forbehold for konstruktionsforbedringer! **CZ** Technické znázornění a rozměry – i na obrázcích a výkresech – jsou nezávazné. Konstrukční změny vyhrazeny! **PL** Prezentacje techniczne i dane wymiarowe – także na rysunkach – są niewiązące. Zmiany konstrukcyjne zastrzeżone! **RU** Иллюстрации технических деталей и указанные размеры, в том числе на рисунках и чертежах, являются ориентировочными. В конструкции возможны изменения! **TR** Teknik resimler ve ebat bilgileri – fotokopi ve çizimler dahil – bağlayıcı değildir. Konstrüksiyon düzeltmeleri saklı tutulmaktadır! **GR** Οι τεχνικές απεικονίσεις και οι διαστάσεις – ακόμα και αυτές που εμφανίζονται στα σχέδια – δεν θεωρούνται δεσμευτικές. Διατηρούμε την επιφύλαξη κατασκευαστικών βελτιώσεων! **JP** 技術データおよび寸法は、改良などによって変更されることがあります。 **CN** 技术图纸和数据 (即使在插图和图纸中) 均不具备法律效力。公司保留进行设计更改的权利！

DISPENSA Junior III

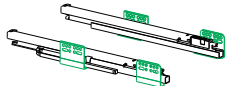

DISPENSA Junior III



1.3  1x  6x $\varnothing 4$ 16 oder oder $\varnothing 6,3$ $\varnothing \text{ min } 7,5$  

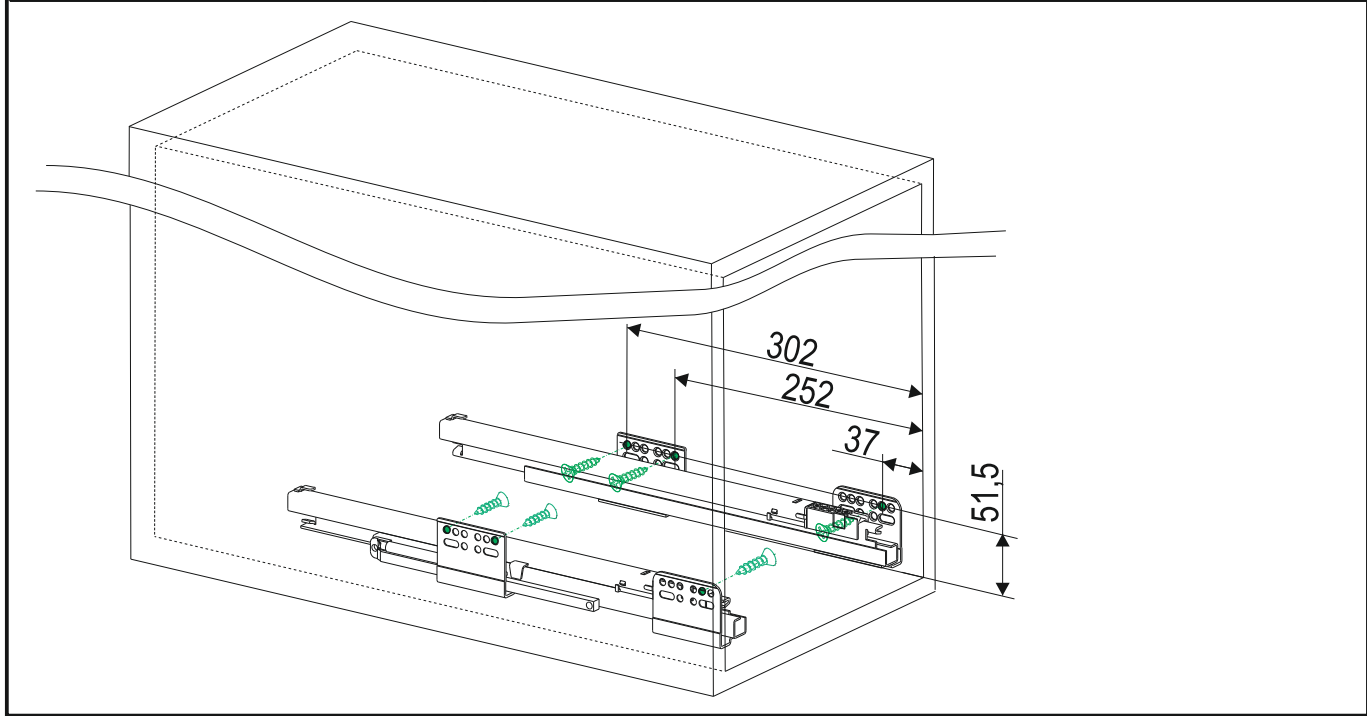

2  1x

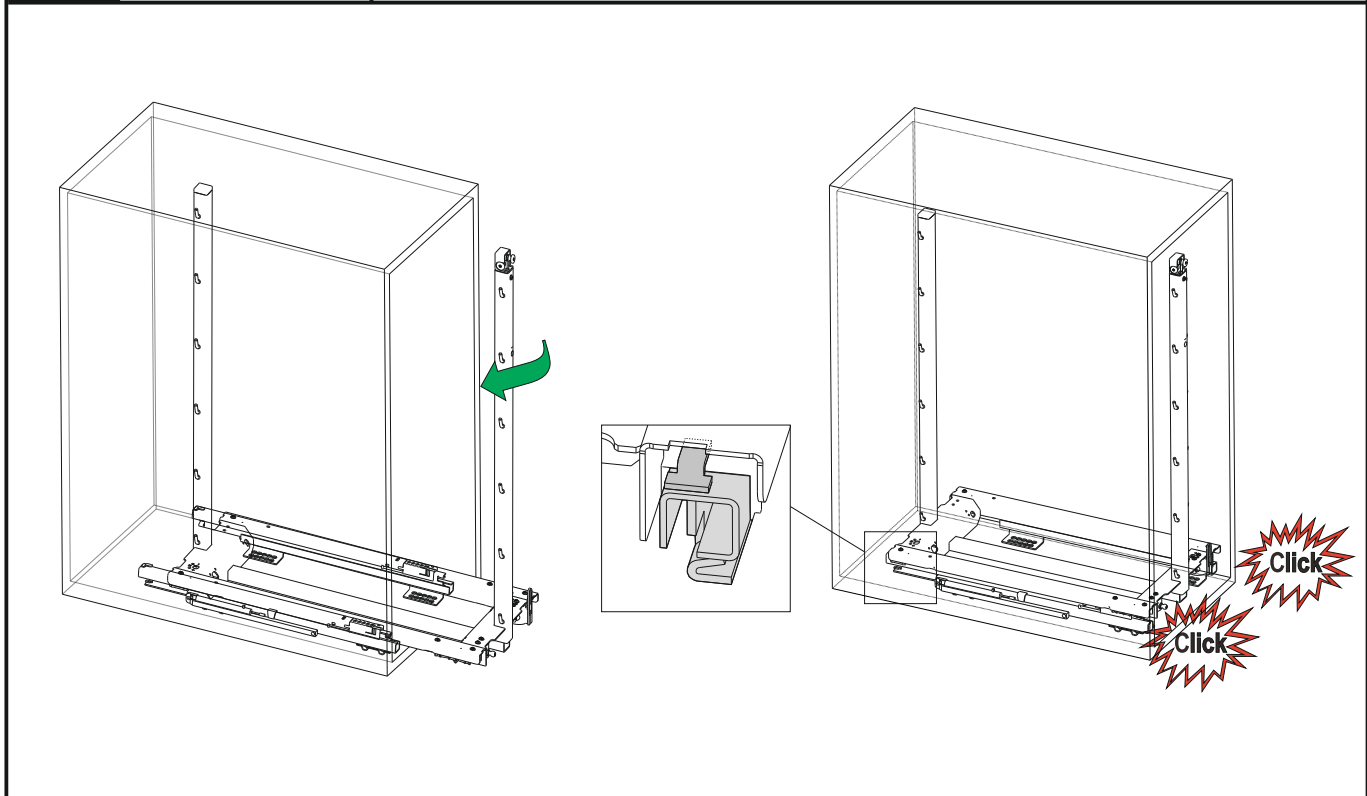

DISPENSA Junior III



3

1x

1x

1x

4x

B	
300	
400	
450	
500	
600	

3a

Alternativ
Alternative
Alternativa

DISPENSA Junior III

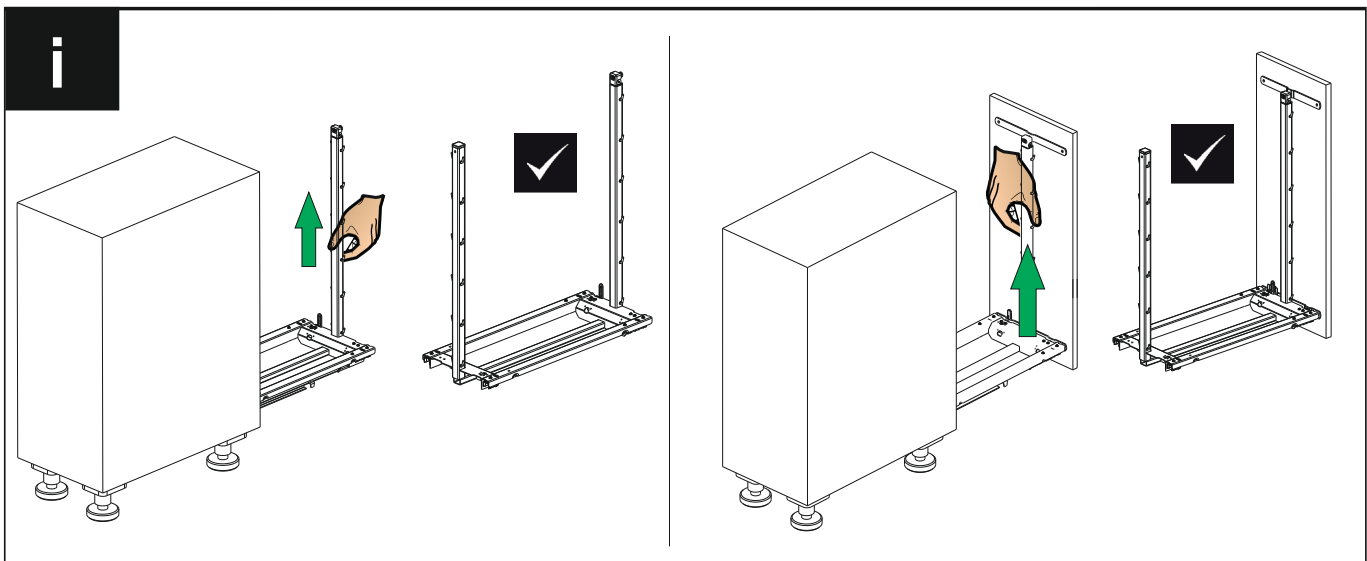
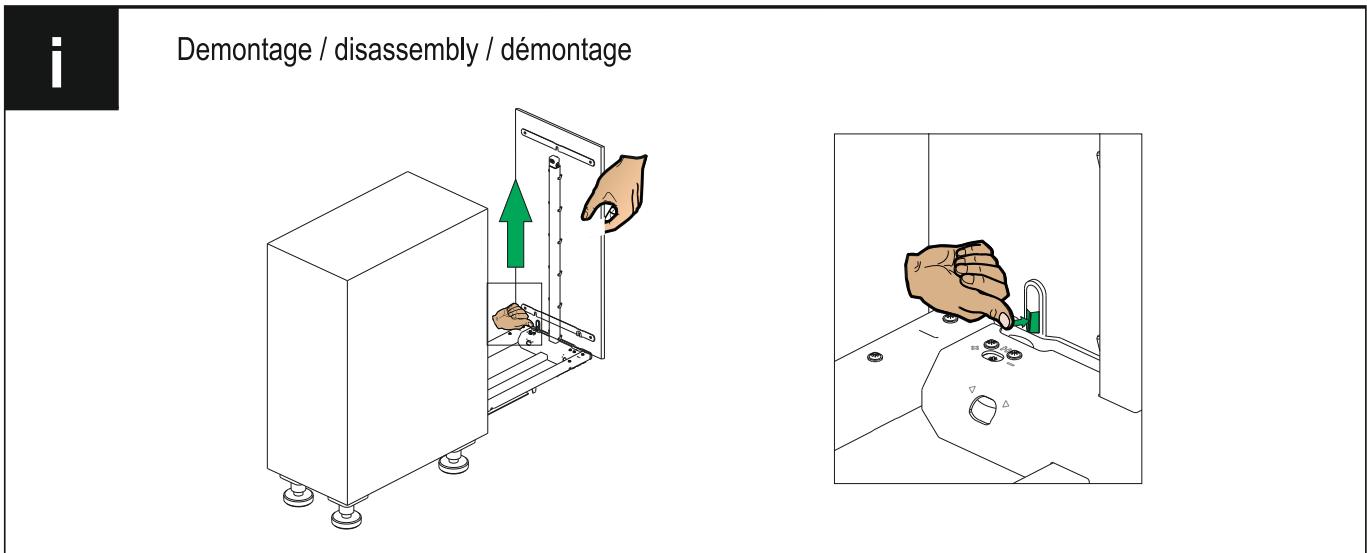
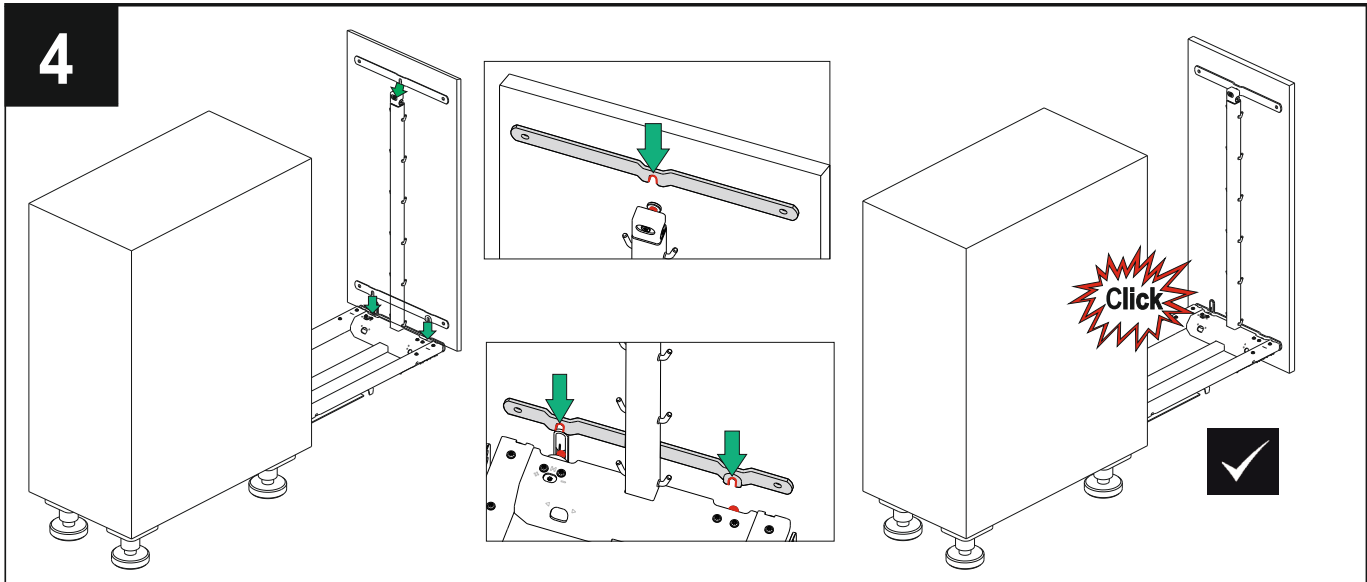

DISPENSA Junior III





<http://support.kesseboehmer.de/dispensa-junior-3>

Justieranleitung

Adjusting Instructions

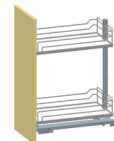
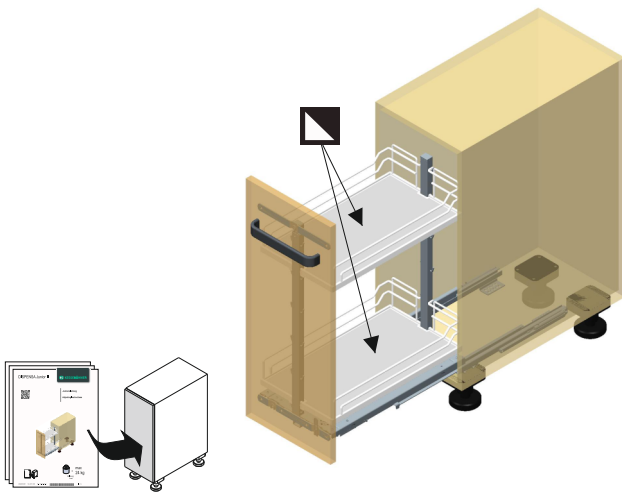
Notice d'ajustment



+  = max 28 kg

Eigengewicht + Beladung
Empty weight + Load
Poids + Chargement

1

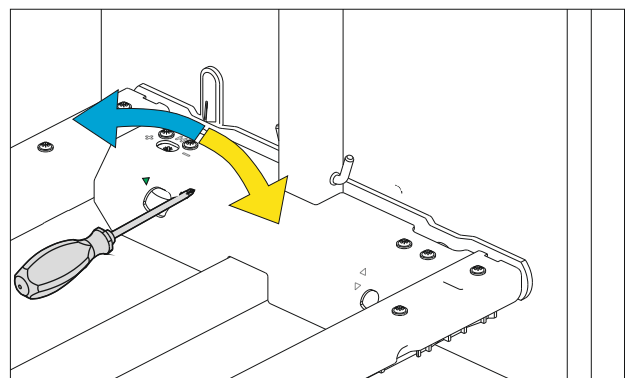
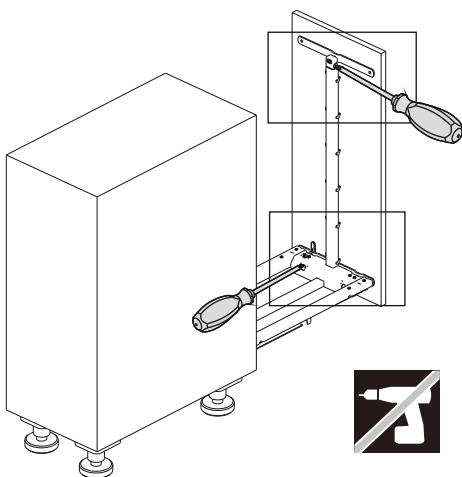
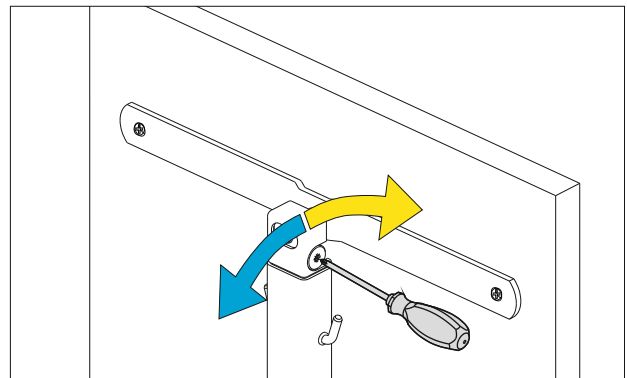
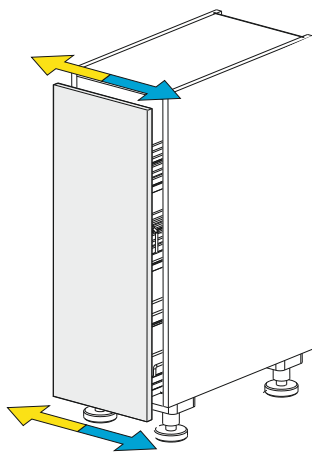

DISPENSA Junior III

